

ESCALATE[®] TRAILER

Model ET 2000 Operation and Service Manual

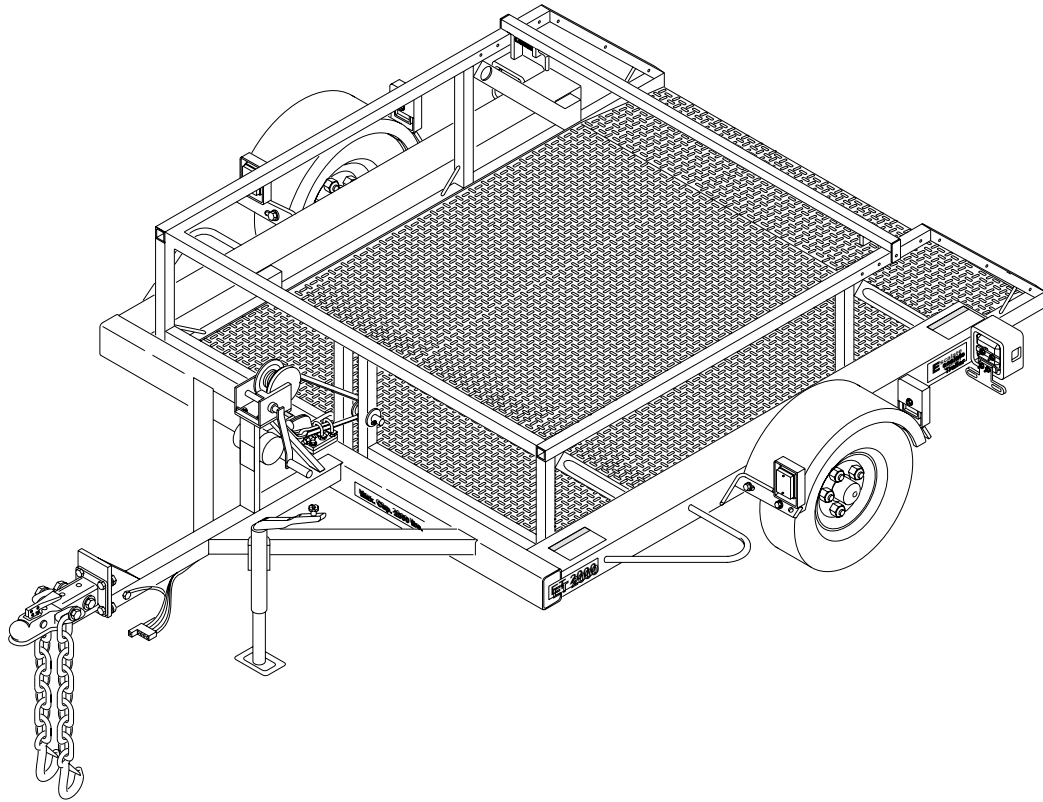

Load Capacity: 2000 lbs

The ET 2000 **ESCALATE[®] TRAILER** offers ground level roll-on loading and roll-off unloading of equipment with *non-tilting* lowering deck. The winch driven deck allows one person to load and unload equipment.

Contents

SAFETY	2
SPECIAL FEATURES	2
SPECIFICATIONS	3
WARRANTY	3
TRAILER HITCHING	5
EQUIPMENT LOADING	6
SERVICE	9
PARTS LIST	12

SAFETY

Warnings and Cautions

Observe all warning labels on the trailer. The trailer warning labels are shown here as a reminder. Other warnings and cautions are included in this manual.

Failure to observe all warnings may result in serious injury or death. Failure to observe all cautions may result in equipment damage.

WARNING

Stand clear of trailer while deck is being raised or lowered. Moving deck will create pinch points causing serious crushing injury.



WARNING

Stand clear of trailer while deck is being lowered. Contact with trailer deck will cause serious crushing injury.



WARNING

Trailer deck must be fully raised with transport clamp locked and pinned before towing trailer.

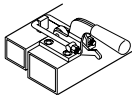

Failure to comply with these instructions may result in serious personal injury or death as well as damage to cargo.

SPECIAL FEATURES

The Bil-Jax ESCALATE[®] TRAILER includes all the features of a heavy duty trailer, plus:

Escalator Deck and Winch

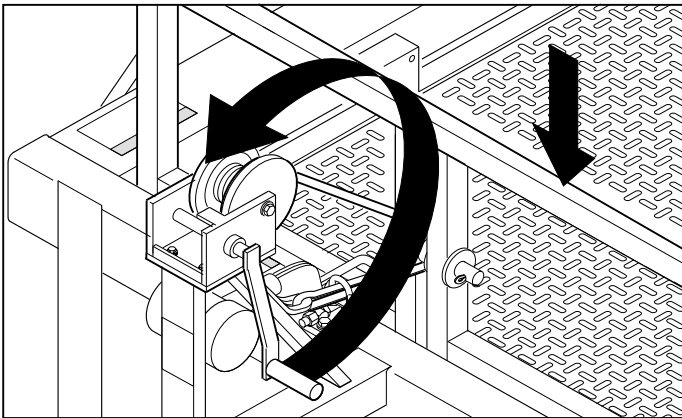

Adjustable Bumper Bar

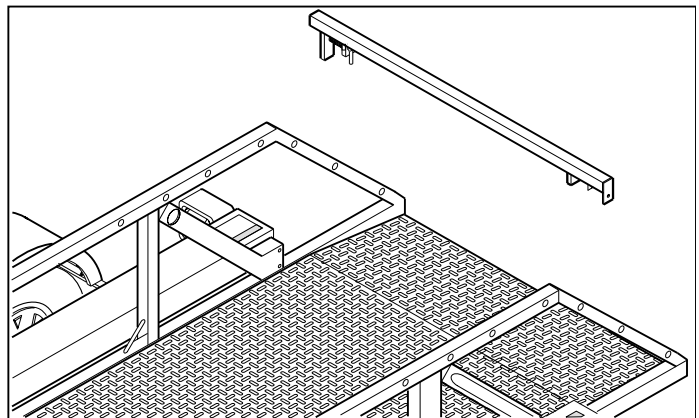

Adjustable Hitch

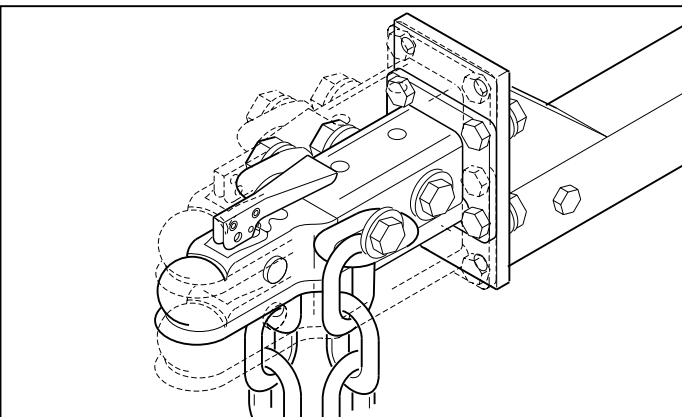

Stow-away Trailer Jack

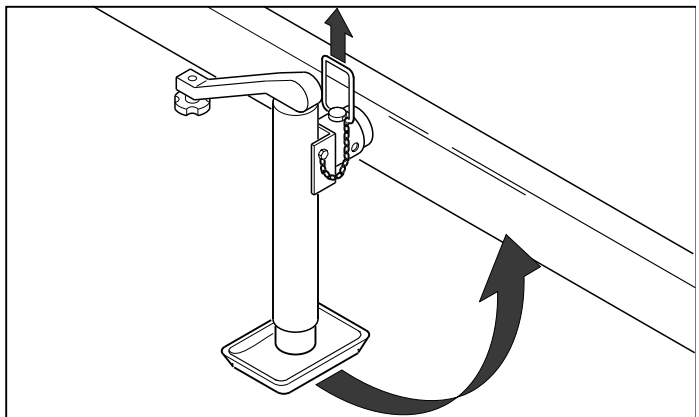

ESCALATE[®] TRAILER

Model Number ET 2000

Serial Number _____

Manufactured by: Bil-Jax, Inc.
125 Taylor Parkway
Archbold, Ohio 43502
419.445.9675

Specifications

Rated Capacity	2000 lbs. (907.2 kg) max.
Weight (Empty)	800 lbs. (362.9 kg)
Overall Width	96 in. (243.8 cm)
Overall Length	148 in. (375.9 cm)
Overall Height (Bed Raised)	32 in. (81.3 cm)
Bed Height (Raised)	13-1/2 in. (34.3 cm)
Bed Size (Flat Surface)	58 in. wide x 72 in. long (147.3 cm wide x 182.9 cm long)
Overall Bed Size (Including Ramp)	58 in. wide x 86 in. long (147.3 cm wide x 218.4 cm long)
Ramp Grade	6 degrees
Hitch Size	2 in. (5.08 cm) ball
Suspension	Leaf Spring

WARRANTY

Bil-Jax warrants its trailers for one year from the date of delivery against all defects of material and workmanship, provided the unit is operated and maintained in compliance with Bil-Jax's operating and maintenance instructions; structural components are also warranted for one year. Bil-Jax will, at its option, repair or replace any unit or component part which fails to function properly in normal use.

This warranty does not apply if the trailer and/or its component parts have been altered, changed, or repaired without the consent of Bil-Jax or by anyone other than Bil-Jax or its factory trained personnel, nor if the trailer and/or its components have been subjected to misuse, negligence, accident or any conditions deemed other than those considered as occurring during normal use.

Components not manufactured by Bil-Jax are covered by their respective manufacturers warranties. A list of those components and their warranties is available upon written request to Bil-Jax.

Bil-Jax shall not in any event be liable for the cost of any special, indirect or consequential damages to anyone, product, or thing. This warranty is in lieu of all other warranties expressed or implied. We neither assume nor authorize any representative, or other person, to assume for us any other liability in connection with the sale, rental, or use of this product.

This page intentionally left blank

Hook Up the Trailer

1. Raise trailer and lift ball latch.

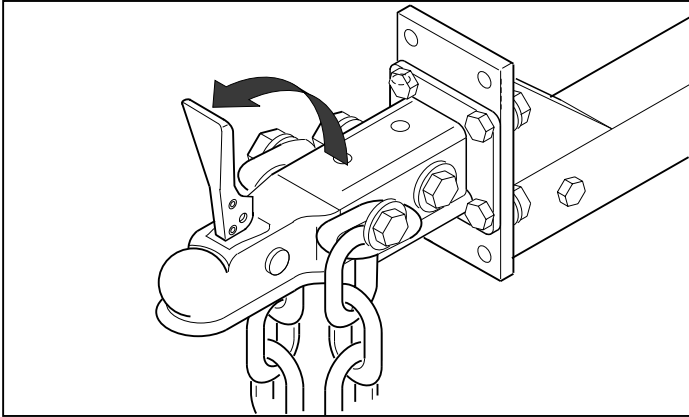

2. Line up ball with hitch.

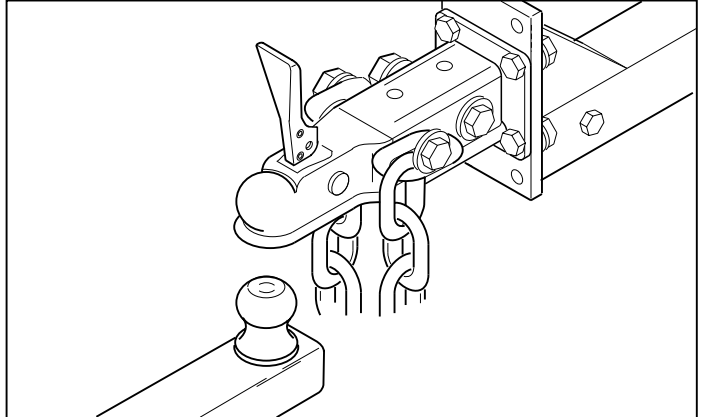

NOTE: The trailer hitch uses a 2 inch ball.

3. Lower hitch onto ball and close ball latch.

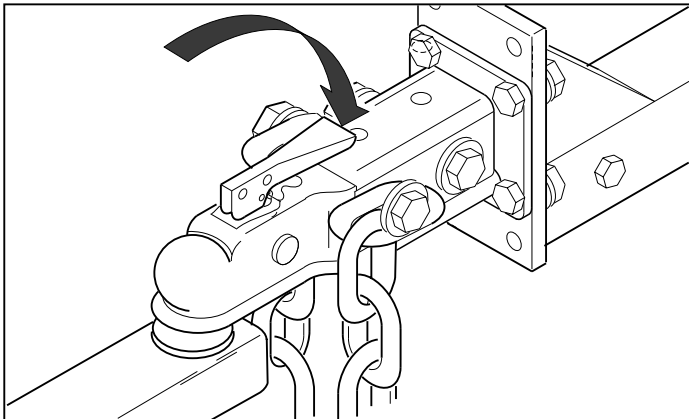

NOTE: Trailer frame should be level when hitch is on ball. See page 9 to change hitch height.

4. Raise and secure jack.

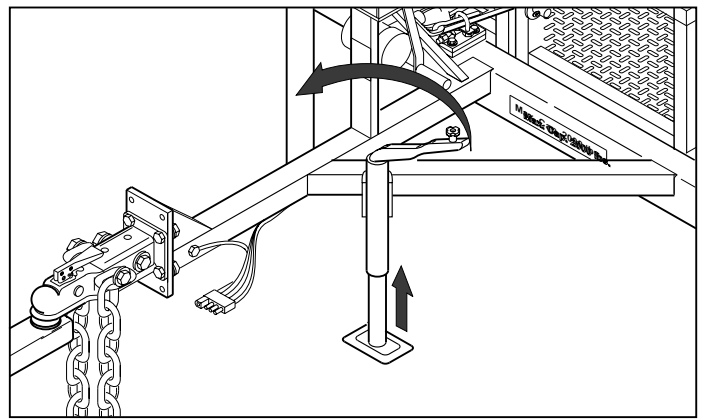

CAUTION

Always raise and pin the jack before towing.

5. Hook safety chains.

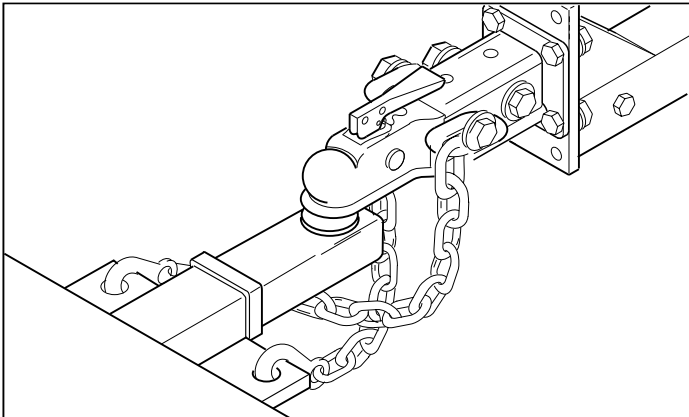

CAUTION

Always cross safety chains below tongue. Safety chains must hold tongue up if hitch fails.

6. Connect and check trailer lights.

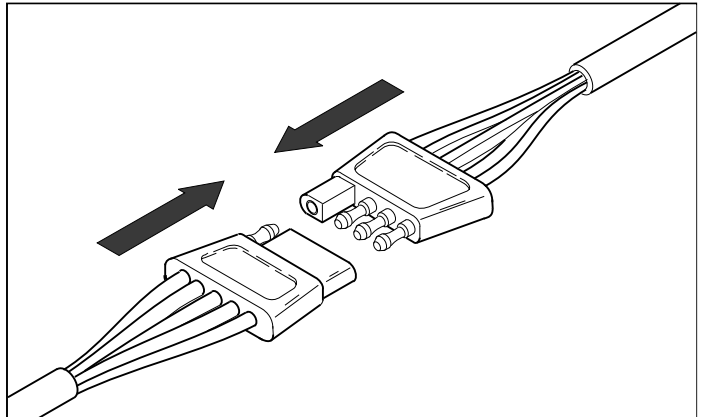

CAUTION

Always check the tail lights and brake lights before towing.

EQUIPMENT LOADING

Lower the Deck

NOTE: Trailer must be hitched to vehicle according to page 5 before lowering or raising the deck.

1. Lift latch release lever.

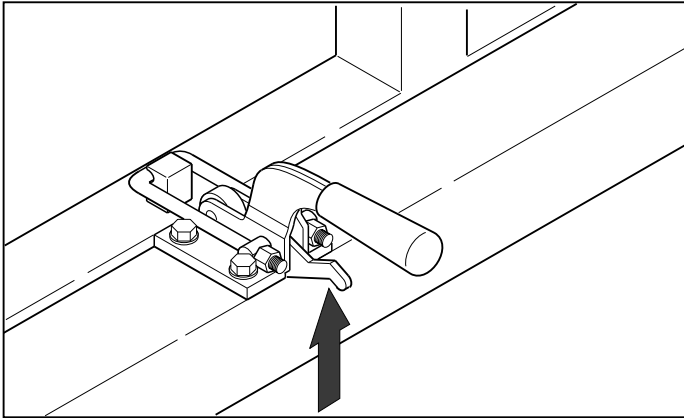

NOTE: The trailer frame should be on a level surface when lowering the deck.

2. Lift latch handle.

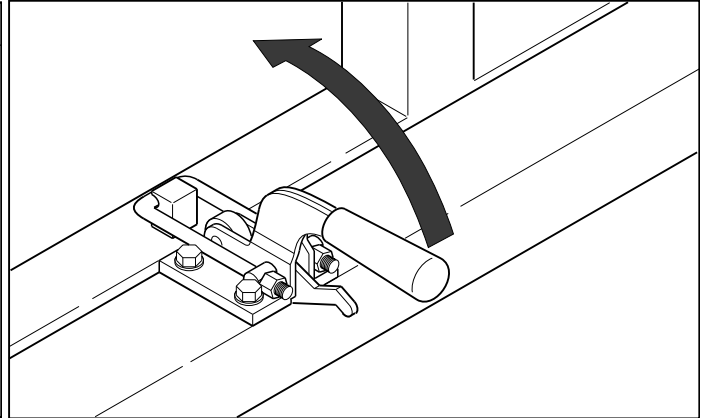

NOTE: If the deck pulls against the clamp when the latch handle is up, the winch brake must be adjusted. See page 9 to adjust the winch brake.

3. Lift latch clamp.

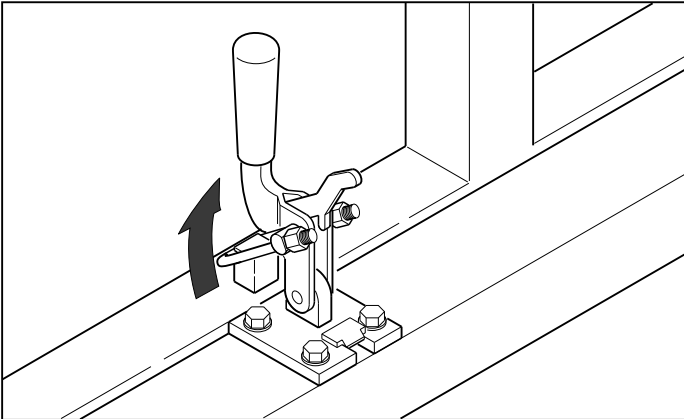

NOTE: To prepare for raising the deck, tilt the latch clamp back onto the handle.

4. Lower the deck.

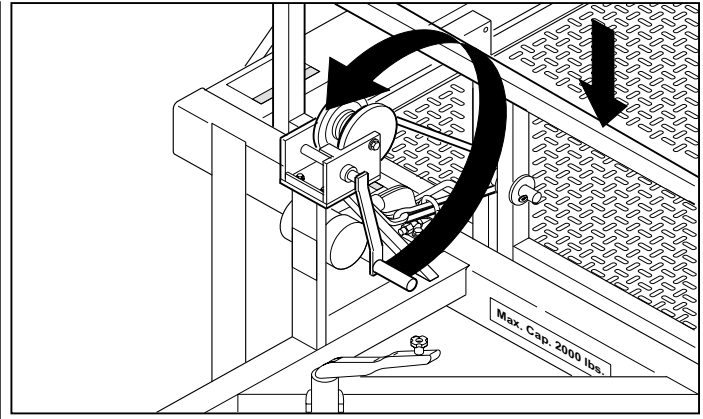

WARNING

Make sure people are away from the trailer before lowering the deck. Keep hands and feet away from deck and rails. Hands and feet can get crushed between the deck and frame.

Load the Equipment

1. Remove bumper bar.

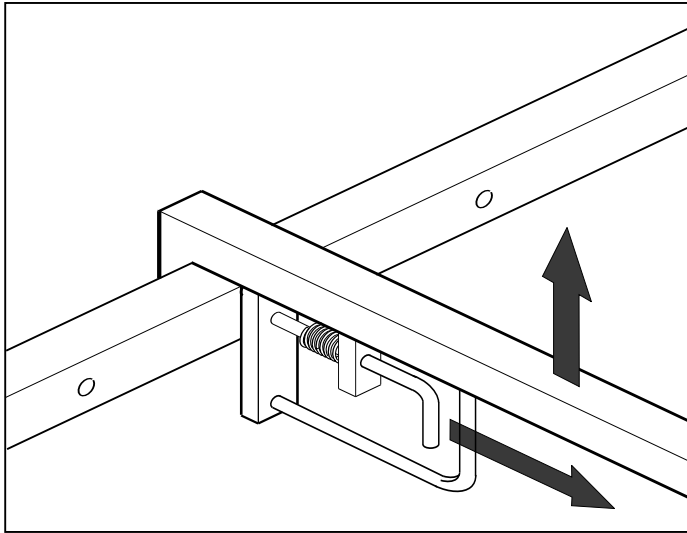

2. Load equipment so that the resulting tongue weight is 15 to 20% of the total load.

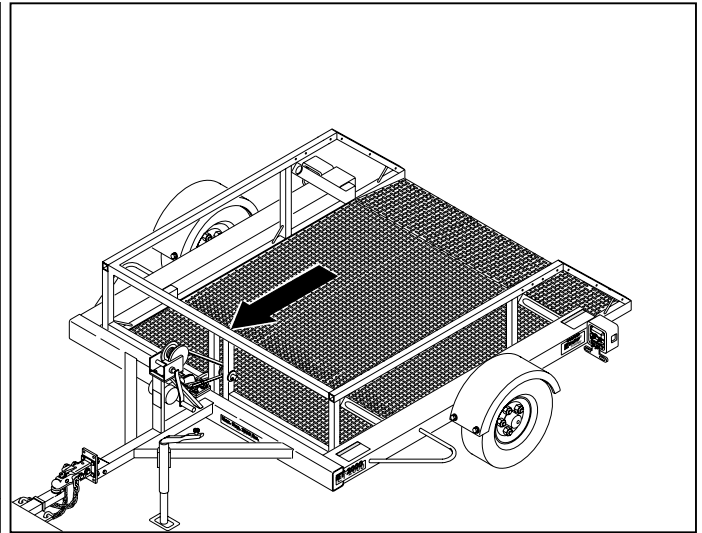

WARNING

Maximum capacity = 2000 lbs. Do not exceed.

3. Install bumper bar close to the rear of the loaded equipment.

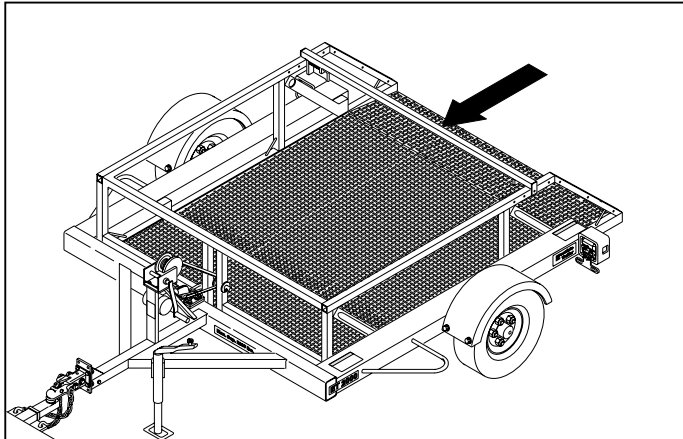

4. Install tie-down straps to keep the load from shifting. Use tie-down anchors shown.

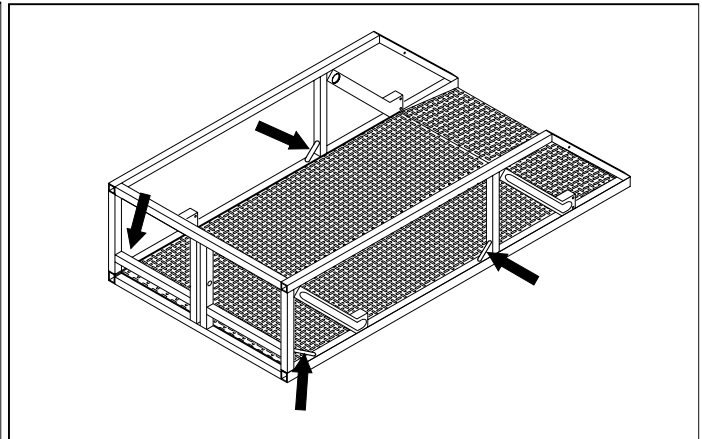

WARNING

Always secure the load with tie-down straps before towing. Failure to properly secure the load may result in injury, death, or equipment damage.



CAUTION

Do not hook tie-down straps on the roller guides.

EQUIPMENT LOADING

Raise the Deck (trailer must be hitched to vehicle)

1. Check the latch clamp. Tilt the latch clamp back onto the handle.
2. Crank winch handle to raise the deck. Stop cranking when the deck is aligned with the frame.

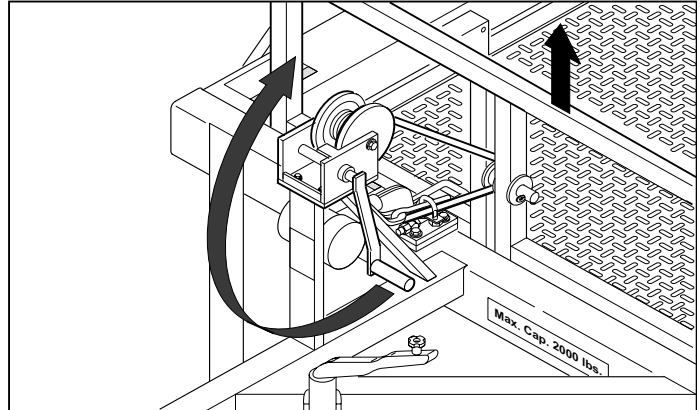
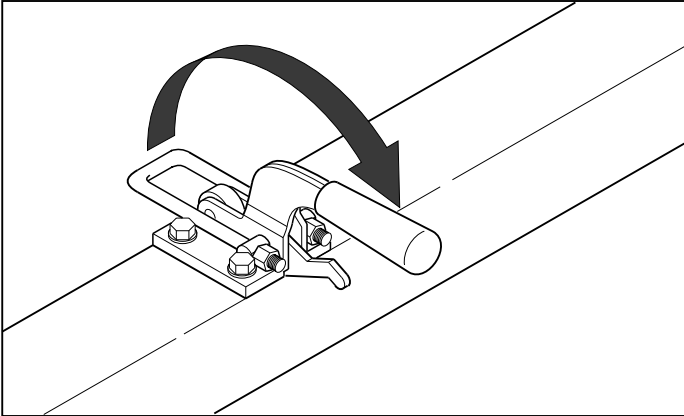

WARNING

Make sure people are away from the trailer before raising the deck. Keep hands and feet away from deck and rails. Hands and feet can get crushed between the deck and frame.

3. Raise the latch handle. Put the latch clamp over the clamp boss.
4. Push the latch handle down until the release lever locks.

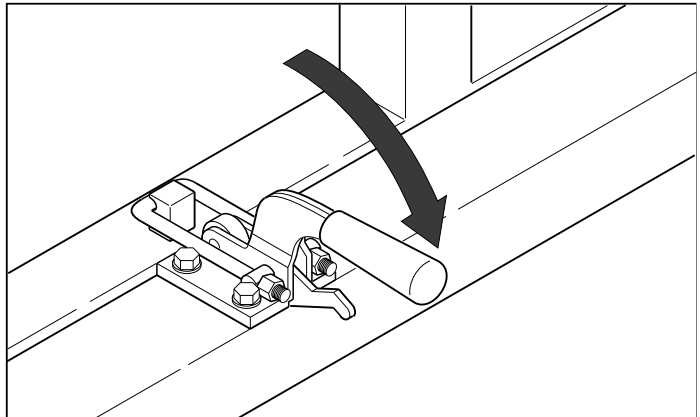
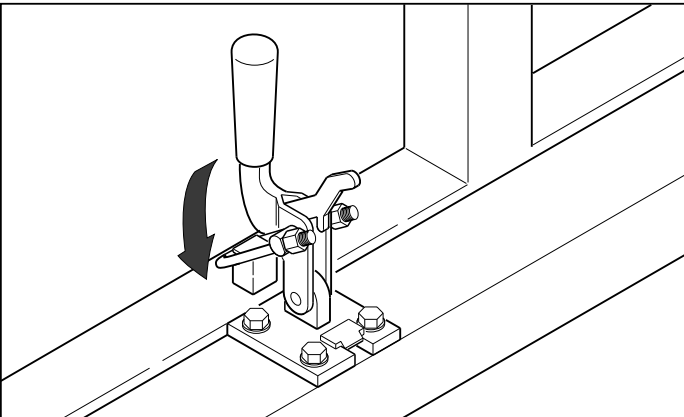

NOTE: Do not over tighten winch. Winch is intended to raise and lower deck — not to secure load on trailer.



WARNING

If not clamped, the deck may fall during travel. Always clamp the deck before towing. Failure to clamp the deck may result in injury, death, or equipment damage.

Adjusting the Hitch Height

The trailer frame and deck should be level for equipment loading and unloading. If the trailer hitch is too high or too low when hitched to the towing vehicle, readjust the hitch height.

1. Unhitch trailer. Remove hitch mounting screws.
2. Install hitch in new position.

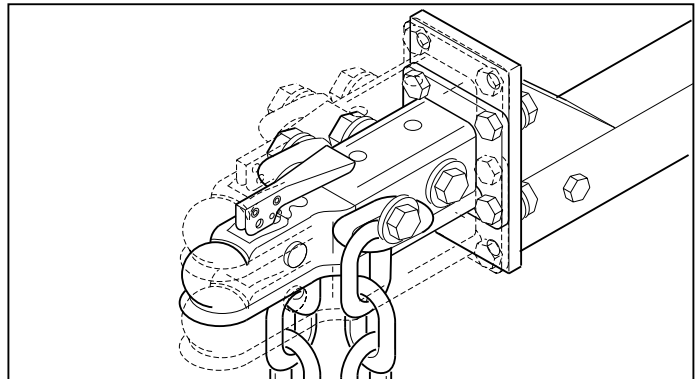
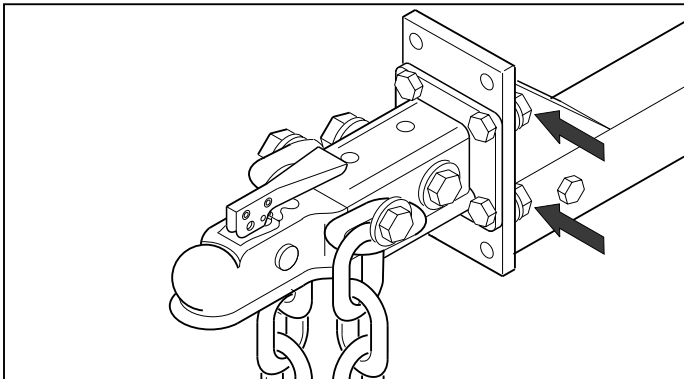

CAUTION

Adjust hitch height when trailer is empty. Use jack to aid in hitch adjustment.

CAUTION

Failure to install and tighten all hitch mounting screws may cause serious equipment damage.

Adjusting the Winch Brake

The winch brake should hold the trailer deck up when the equipment load is not more than 2000 pounds. If the winch brake does not hold the deck up when the winch handle is released, readjust brake tension.

1. Raise the deck.
2. Remove the winch handle and lock nuts.

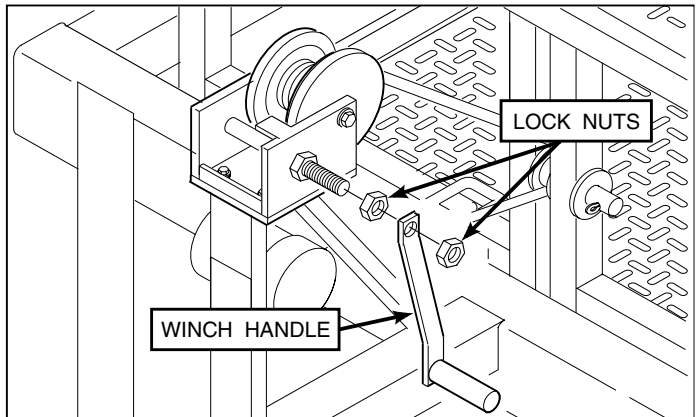
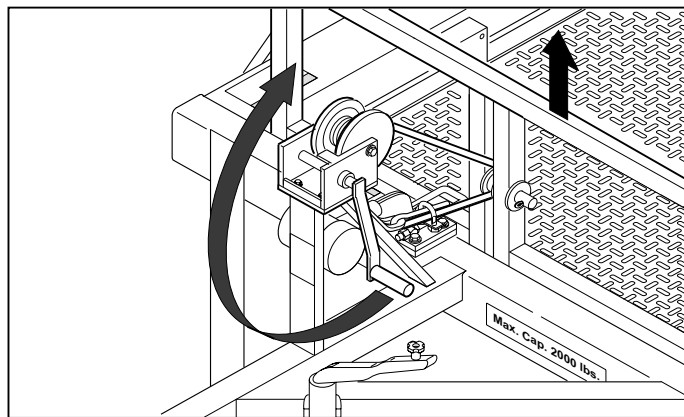

3. Tighten the winch brake adjust nut 1/4 turn.
4. Install and tighten the lock nuts and handle.

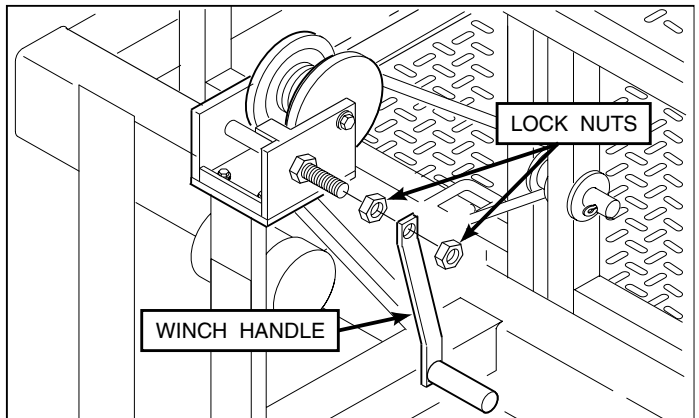
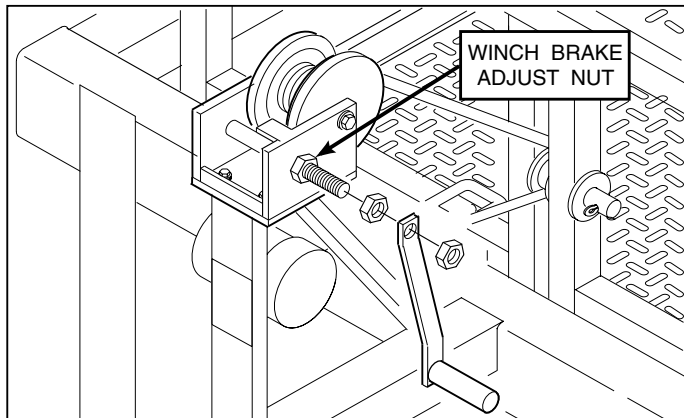

Replacing the Lift Rollers

1. On a paved, level surface, pull trailer onto 2x6 blocks. Jack up and unhitch the trailer.

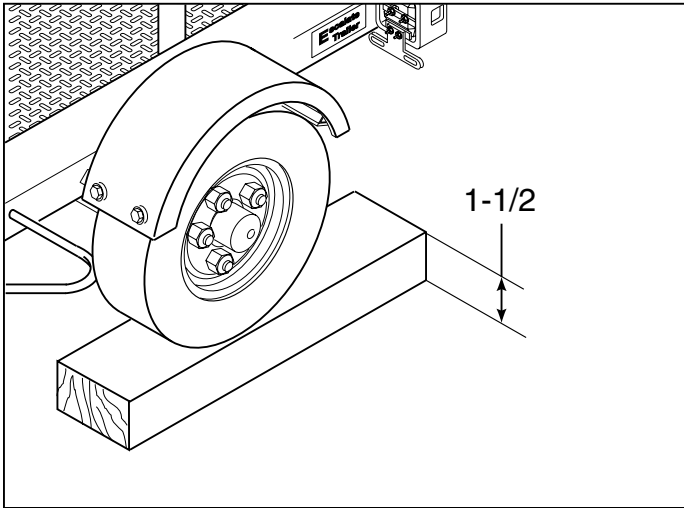

2. Lower the deck until the front or rear lift rollers can be removed from the roller access holes.

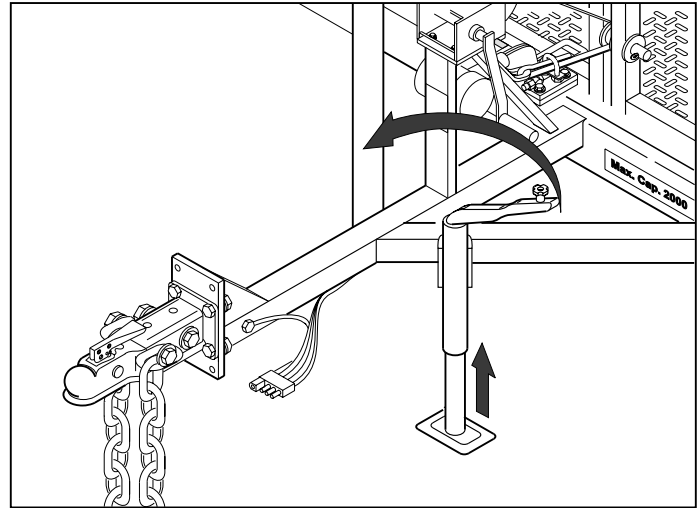

CAUTION

The deck must be supported by the paved surface or shoring before the lift rollers are removed.

3. Use a hex wrench to unscrew and remove the rollers. Install and tighten new rollers.

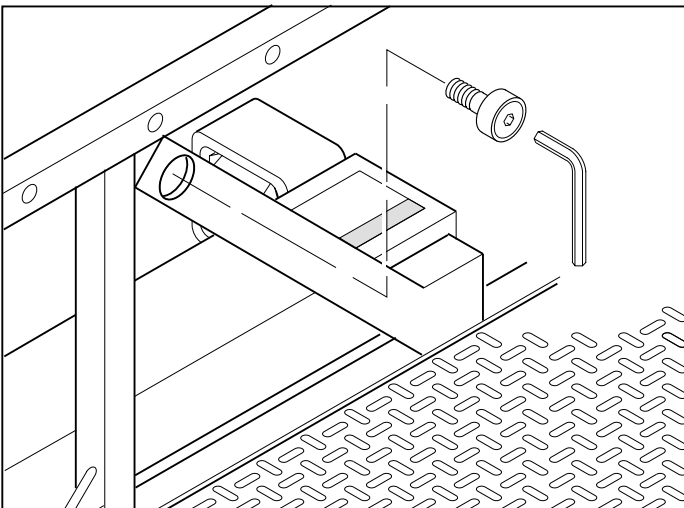



NOTE: It is easier to remove and replace one roller at a time. You can adjust the jack to access each roller. Loosen set screw first.

SERVICE

Tire Maintenance

At least once each week, use an accurate tire pressure gage to check the air pressure in both trailer tires. Inflate to the pressure recommended by the tire manufacturer (located on the tire).

 CAUTION
Low or uneven tire pressures will not properly support a loaded trailer and could lead to premature tire wear.
 WARNING
When replacing tires, it is important to use a tire of appropriate size and load rating (20.5/800X10E).
 WARNING
Failure to maintain proper torque on the lug nuts may result in the wheel shearing off of the trailer, possibly causing an accident and seriously damaging the equipment.

Wheel Torque Requirements

It is extremely important to apply and maintain proper wheel mounting torque on your axle. Wheel nuts should be retorqued after 50 miles and 100 miles and periodically there after.

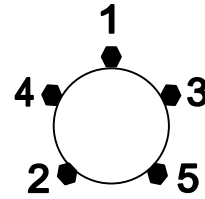

The tightening of the lug nuts should be torqued in the sequence above.

Lug nuts should be torqued in stages:

Stage 1	Stage 2	Stage 3
25 Ft-Lbs	60 Ft-Lbs	100 Ft-Lbs

This procedure should be followed after each time the tire is removed.

Lubrication (every 6 months)

Lubricate the following parts with clean motor oil where shown.



or wheel bearing grease

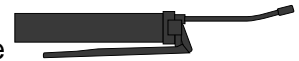

For additional winch operating and service instructions, refer to the Winch Owner's Manual. The Winch Owner's Manual is in the storage tube at the front of the trailer.

NOTE: Be sure that no grease is applied to brake pad.

Wheel Bearings

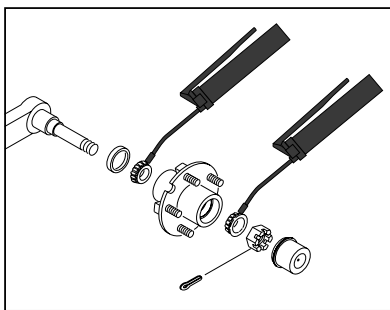

Jack

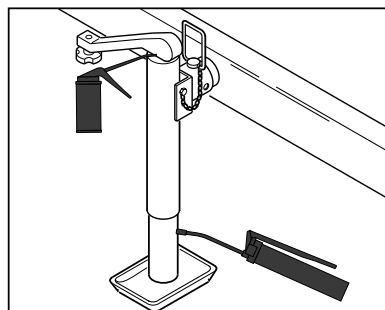

Winch

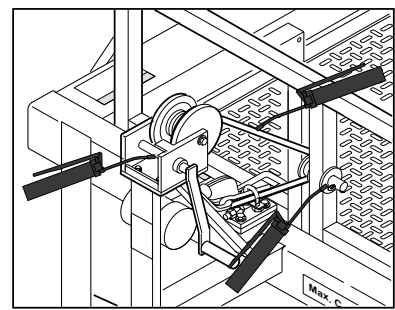

Hitch

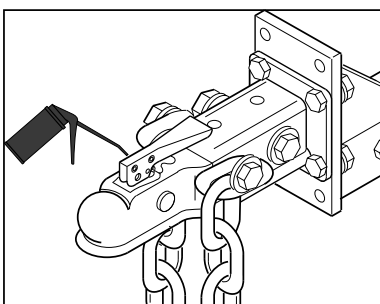

Deck Latch

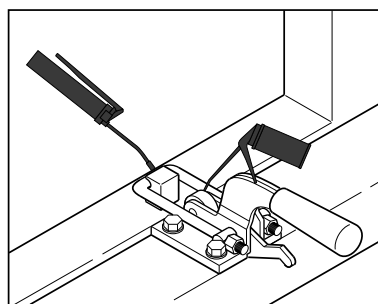

Bumper Bar

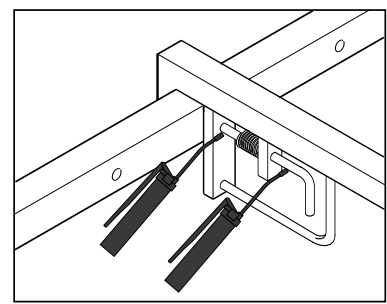

PARTS LIST

Item No.	Part No.	Description	Qty
1	B12-00-0046	Deck Weldment	1
2	B12-00-0053	Load Bar Weldment	1
3	0089-132	Spring, Compression	2
4	0090-0313	Pin, Roll, 3/16 x 3/4	2
5	0066-0063	Pin, L	2
6	B07-06-5456	Plate, Spring Push-Off	2
7	B39-00-0023	Spring, Compression, 7/8 in.	2
8	0090-0051	Screw, Cap, 3/8-16 x 2-3/4	2
9	B12-00-0047	Frame Weldment	1
10	0090-0363	Screw, Set, 1/4-20 x 3/4	4
11	B25-00-0048	Roller, Lift	4
12	0090-0034	Screw, Cap, 5/16-18 x 2	8
13	0090-0208	Washer, Split Lock, 5/16	8
14	0090-0420	Washer, SAE Flat, 5/16	20
15	B18-00-0109	Fender	2
16	B06-00-0313	Decal, "Stand Clear While..."	2
17	B01-10-0024	Light Assembly, Left Tail	1
17A	B01-10-0023	Light Assembly, Right Tail	1
17B	B01-10-0070	Lamp, Tail Light, GE-1157	2
17C	B01-10-0069	Replacement Lens	2
18	B06-00-0317	Decal, "Escalate Trailer"	2
19	0090-0005	Screw, Cap, 1/4-20 x 3/4	2
20	B29-00-0037	Bracket, License Plate	1
21	0090-0419	Washer, SAE Flat, 1/4	2
22	0090-0183	Nut, Lock, 1/4-20	2
23	0090-0907	Shackle Bolt, 9/16-18 x 3	2
24	0192-0042	Hub Group, (items 25 thru 27 and 29)	2
25	B32-00-0009	Seal, Bearing	2
26	B25-00-0056	Bearing, Wheel	4
27	0192-0103	Hub, 5 Hole, 4.5 in. BC	2
28	0090-0882	Washer, Spindle	2
29	B32-00-0011	Cap, Hub	2
30	0090-0881	Pin, Cotter, 5/32 x 2	2
31	0090-0278	Nut, Castle, 1-14	2
32	0192-0097	Wheel/Tire Assembly 20.5/800X10E	2
33	0090-0624	Nut, Wheel Lug	10
34	B39-00-0024	Spring, Leaf	2
35	B07-06-5262	Plate, Hanger, Leaf Spring	4
36	0090-0185	Nut, Nylon Lock, 5/16-18	8
37	B31-00-0028	Cushion, Leaf Spring	2
38	B07-06-5263	Bracket, Leaf Spring Hanger	2
39	0090-0037	Screw, Cap, 5/16-18 x 2-1/2	8
40	B06-00-0319	Decal, ET 2000	2

Item No.	Part No.	Description	Qty
41	B06-00-0316	Decal, "Max. Cap. 2000 lbs."	1
42	B23-02-0036	Jack, Tongue	1
43	0090-0344	Screw, Threadcut, #10-24 x 1/2	1
44	B01-01-0120	Harness, Wiring, 20 ft.	1
45	0090-0574	Washer, SAE Flat, 1/2	6
46	0090-0080	Screw, Cap, 1/2-13 x 4-1/2	2
47	0090-0081	Screw, Cap, 1/2-13 x 5	1
48	0090-0192	Nut, Nylon Lock, 1/2-13	7
49	B03-00-0017	Safety Chain Assembly	2
50	0192-0099	Hitch, Ball, 2 in., 3500 lbs.	1
51	0090-0068	Screw, Cap, 1/2-13 x 1-3/4	4
52	B12-00-0049	Hitch Weldment	1
53	Not Replaceable	Serial Number Tag	1
54	B00-00-0014	Cap, Plastic, 2-1/2 in. Dia.	2
55	0082-0867	Winch, w/o Cable	1
56	0090-0422	Washer, Flat, SAE, 3/8	3
57	0090-0210	Washer, Split Lock, 3/8	7
58	0090-0040	Screw, Cap, 3/8-16 x 3/4	7
59	B04-07-0047	Clamp, Cable 1/4 in.	2
60	B05-03-0001	Cable, Steel, 1/4 in.	7ft.
61	B00-00-0036	Thimble, Cable, 1/4 in. Dia.	1
62	B42-00-0012	Latch, Deck	1
63	B06-00-0314	Decal, "Lock Transport ..."	1
64	Purchased with jack (item 43)	Pin, Retaining	1
65	B06-00-0312	Decal, "Stand Clear ..."	2
66	0090-0906	Shackle Nut, 9/16-18	2
67	0090-0429	Washer, SAE Flat, 1 in.	1
68	B26-00-0016	Pulley	1
69	0090-0770	Pin, Cotter, 3/16 x 1-1/2	1
70	B36-00-0027	Pin, Pulley	1
71	B29-00-0147	Bracket, Side Marker Light, Left Front/Right Rear	2
72	B01-10-0021	Light, Side Marker, Left/Right Front – Amber	2
72A	B01-10-0066	Replacement Lens – Amber	2
72B	B01-10-0068	Lamp, Side Marker	2
73	B29-00-0146	Bracket, Side Marker Light, Left Rear/Right Front	2
74	B01-10-0022	Light, Side Marker, Left/Right Rear – Red	2
74A	B01-10-0067	Replacement Lens – Red	2
74B	B01-10-0068	Lamp, Side Marker	2

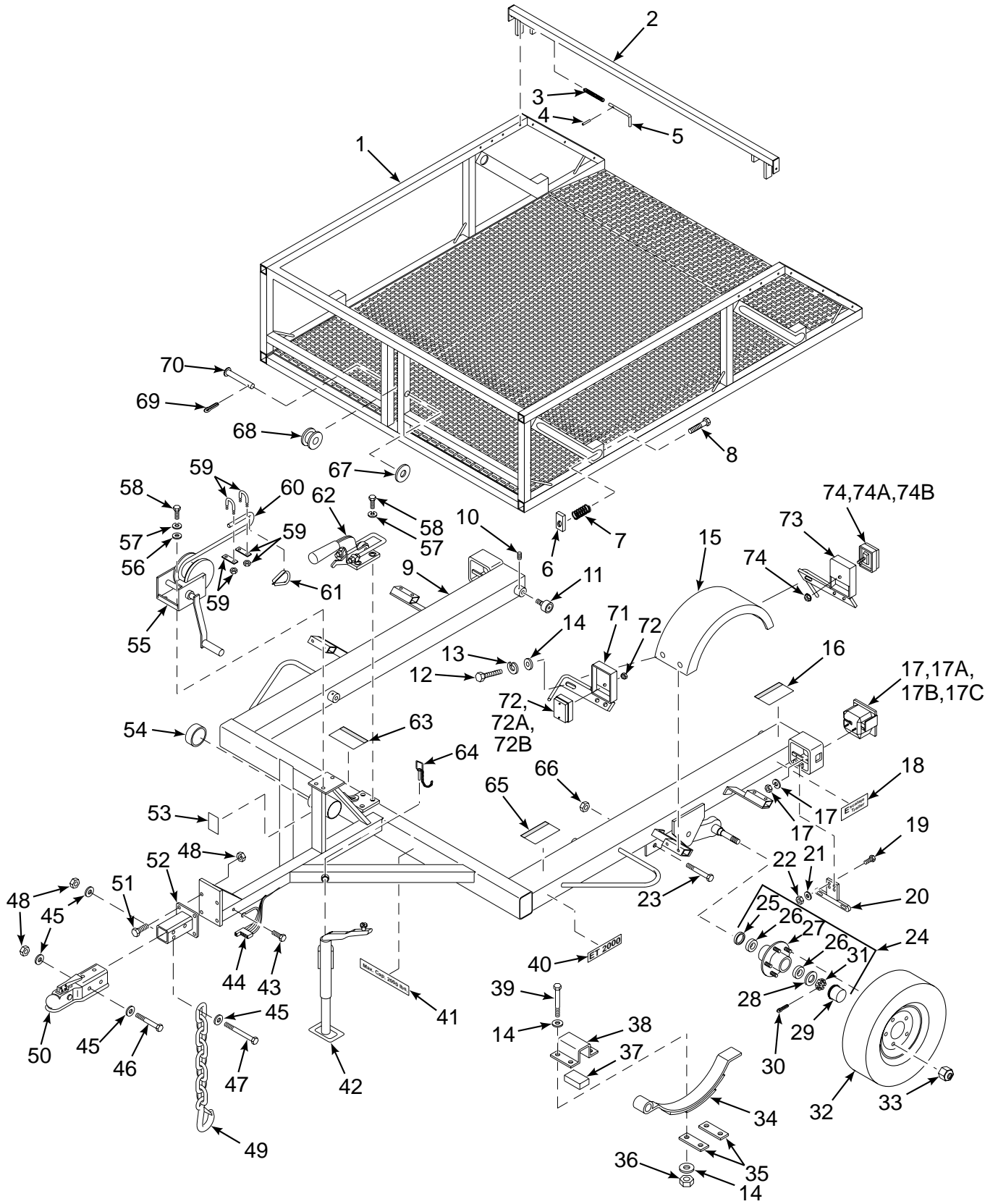

Model ET 2000 ESCALATE® TRAILER



125 Taylor Parkway Archbold, OH 43502

Phone 419-445-9675 Fax 419-445-0367